

EN



PRODUCT CATALOGUE

INDEX

OUR HISTORY	pag 2
PUMP CATEGORIES	pag 4 - 5
VERTICAL PUMPS	pag 6 - 15
HORIZONTAL PUMPS & FRONT SUCTION	pag 17 - 24
PUMPS FOR CLEAR WATER PUMPING UNIT	pag 25
SUBMERGED PUMPS	pag 27 - 30
OTHER PUMPS	pag 31
VALVES	pag 33 - 34
PIPES & FLANGES	pag 35
SPARE PARTS	pag 36



Since 1971 Alfa Pompe has been designing, engineering and manufacturing centrifugal pumps for wastewater and sludge from industrial processes, suitable for abrasive and acidic liquids. Alfa Pompe inBODYrated the EIR brand, a historic Italian company that has been producing centrifugal pumps since the 1950s in various industrial and manufacturing sectors.

Today Alfa Pompe is present in several countries around the world through its sales and service network. Alfa is continuously developing new solutions for even the most demanding industries, such as mining, aggregate quarries, concrete mixing plants, ceramics, marble and granite processing and many others.

Alfa pumps are designed and built specifically for different industries and applications. Performance is developed to meet any requirement for pumping abrasive liquids, acids, liquid and dense slurries.

The materials used to manufacture Alfa pumps range from spheroidal cast iron to super alloys, depending on industrial applications. The pump bodies can be internally coated with abrasion-resistant rubber (either with externally adjustable interchangeable diaphragms or by vulcanisation).

All pumps can be driven by inverters. This allows great adaptability to the system served.

The design, materials and construction of Alfa pumps make them particularly wear-resistant and easy to maintain.



**ALFA POMPE
SINCE 1971**

CATEGORIES

VERTICAL PUMPS

Vertical axis pumps that find application in tanks or shafts, designed to handle sludge produced in the marble and granite industry, in mining, in the treatment/washing of aggregates or in the ceramic industry. They are characterised by bearings dimensioned in such a way as to allow the lower part of the shaft to work without supports immersed in the liquid. They can be coated in anti-abrasive rubber or super hard cast iron depending on the application. They can be supplied with transmission via belts and pulleys or with direct coupling via a coupling.



HORIZONTAL PUMPS

Pumps used to feed filter presses.

Depending on the area of application, they can be rubberised or made of super hard cast iron. DIABLO, DELTA and HURACAN pumps are specially designed for heavy-duty use in mining or in the washing of aggregates. In the marble and granite industry, on the other hand, the anti-abrasive rubber coating characteristic of our ENOLA, EVO and LEVANTE pumps is prevalent. Horizontal filter press pumps can be supplied with single or double speed motors and with standard coupling by means of belts and pulleys.



FRONT SUCTION PUMPS

WALFPUMP pumps are designed and engineered to feed hydrocyclones but are also used for sludge transfer or for loading filter presses. They are characterised by front suction and can process large flow rates.

Depending on the type of application, they can be fully metallic in super hard cast iron or lined with abrasion-resistant rubber. In the standard version they are supplied with a packing seal (or grease cord) but it is also possible to have them with a mechanical seal.



PUMPS FOR CLEAR WATER PUMPING UNIT

Clear water pumping units that integrate perfectly into the process for water purification and recycling.

Monobloc horizontal axis pumps are used, with bodies and impellers in cast iron, bronze or stainless steel, mechanical seals in widia or steel, shafts in hardened steel or stainless steel.



SUBMERGED PUMPS

Vertical axis pumps that can be totally submerged in the tank or sump. Designed to handle sludge produced in the marble and granite industry, in mining, in the treatment/washing of aggregates or in the ceramic industry. One of the features of these pumps is that the impeller is mounted directly on the motor shaft. They can be coated in abrasion-resistant rubber or super hard cast iron depending on the application.





DISCOVERER

VERTICAL ANTI-ABRASIVE DIRECT-COUPLED PUMP

FIELDS OF APPLICATION:

Special pumps designed and developed for conveying highly abrasive liquids from stone processing (workshops and sawmills), from the treatment washing of aggregates, the recovery of cementitious water and in the glass and ceramic processing sectors.

Vertical axis with sealed chamber bearings dimensioned in such a way as to allow the lower part of the shaft to work overhanging without supports immersed in the liquid.

The special feature of these pumps is the absence of the stuffing box which, in contact with the abrasive liquid, would have a minimal life span.

The application of an anti-abrasive rubber tube is recommended to be placed between the pump delivery curve and the fixed piping of the system for vibration dampening and ease of installation. As this type of pump is not self-priming, the liquid must always cover the body/impeller AXISmbly.

TECHNICAL SPECIFICATIONS:

AXIS: Vertical pump with sealed chamber bearings sized to allow the lower part of the shaft to operate without supports submerged in the liquid.

COUPLING: Coupled by means of an elastic joint, two pieces complete with protective casing.

BODY: Made of cast iron divided into two halves with a protective coating of our special moulded wear-resistant compound, consisting of replaceable shells that can be adjusted from the outside, both to allow rapid and convenient replacement and to eliminate any backlash caused by normal wear. In the smaller series the bodies are vulcanised, with shells only on request.

OUTLET CURVE: With interchangeable rubber sleeve for connecting the pump to the discharge pipe.

IMPELLER: Anti-clogging open-type, consisting of a steel core coated with a special anti-abrasive compound.

SUCTION STRAINER: Made of cast iron, specially sized and shaped for liquid suction.

SUPPORT GROUP WITH RINGBOLT: Usually supplied because they are needed for lifting operations

PUMP STOP: Bracket for fixing the pump to the wall.

EXTENSION TO THE SUCTION STRAINER: On specific request, there is the possibility of inserting an extension between the suction strainer and the lower body in order to increase the distance between the lower bearing and the liquid level, or to allow the electric Engine to remain outside the tank.



OPERATING CHARACTERISTICS

PUMPS	FLOW RATE																												RPM Speed	KW Engine	Ø. m Piping	Ø. m Impeller	Kg/ft Spec. weight
	m3/h	6	9	12	18	24	30	45	60	75	90	105	120	135	150	180	210	240	270	300	330	360	390	420	450	480	510	540					
	l/1'	100	150	200	300	400	500	750	1000	1250	1500	1750	2000	2250	2500	3000	3500	4000	4500	5000	5500	6000	6500	7000	7500	8000	8500	9000					
29	19	18	14	18	10,5																							2860	4	60	135	1,5	
45	11	10,5	10	8,5	7																							1425	4	60	180	1,7	
65			15	14,5	14	13,5	7,5																					1450	7,5	70	210	1,7	
75			17,5	17	16,5	15	13	11																				1455	11	100	240	1,7	
75S				20,5	20	18,5	16,5	14,5	12																			1460	15	100	265	1,7	
101				18,5	18	17	16	15	13,5	12	10																	970	18,5	100	375	1,7	
122						18,5	18	17,5	16,5	16	15,5	15	13,5	12	10													970	22	125	360	1,7	
123								21	20,5	20	19,5	19	18	17	15,5	13,5	12	10										975	30	150	380	1,8	
125								22,5	22	21,5	21	20	18,5	17	15,5	13,5	11,5											975	37	150	400	1,8	
158									15	15	14,5	14,5	14	13,5	13	12	11,5	11	10	8,5								735	37	180	440	1,8	
160											19,5	19	18,5	18	17,5	17	16	15	14	13	12	11	10					980	45	180	390	1,8	
168-168S													17	16,5	16	15,5	15	14,5	13,5	12,5	11,5	10,5	8,5				735	45	180	465	1,8		
168S/455													16	16	15,5	15	14,5	13,5	12,5	11,5	10,5	9					735	45	180	455	1,8		
178													18,5	18	17,5	17	16,5	16	15	14	13	12	10,5				735	55	200	475	2		
198/460														18,5	18	17,5	17	16,5	16	15,5	14,5	14	13	12	11			735	75	200	460	2	
198/470														19,5	19	18,5	18	17,5	17	16,5	16	15	14,5	13,5	12,5	11		735	75	200	470	2	
200															22,5	22	21,5	21	20	19	18	17	16	15	14	13		980	55	200	415	1,8	

Indicative data - pump curve flow rates / Measurement made with water / kW Engines for liquids with indicated specific weight.

OVERALL DIMENSIONS

PUMPS	DIMENSIONS in mm										WEIGHT KG
	A	B	C	D	E	F	G	H	M	N	
29	1755	780	310	165	125	140	325	250	50	1290	135
45	1755	780	310	165	125	175	370	250	50	1290	142
65	2560	1060	420	175	105	205	440	330	70	1990	330
75	2690	1050	415	200	105	260	475	330	100	1990	360
75S	2690	1050	415	200	105	260	475	330	100	1990	375
100	3355	1450	515	205	115	360	580	400	100	2550	730
121	3340	1500	615	420	145	400	610	500	125	2600	790
123	3505	1500	615	420	145	400	610	500	150	2630	910
125	3505	1500	615	420	145	400	610	500	150	2630	950
158	3965	1750	840	310	210	450	810	700	175	2870	1130
160	3965	1750	840	310	210	450	810	700	175	2870	1130
168S	3965	1750	840	310	210	450	810	700	175	2870	1180
178	3995	1750	840	310	210	450	810	700	175	2900	1370
198	4105	1750	840	310	210	465	775	700	200	2910	1650
200	3965	1750	840	310	210	450	810	700	175	2870	1300

Non-binding dimensions and weights.

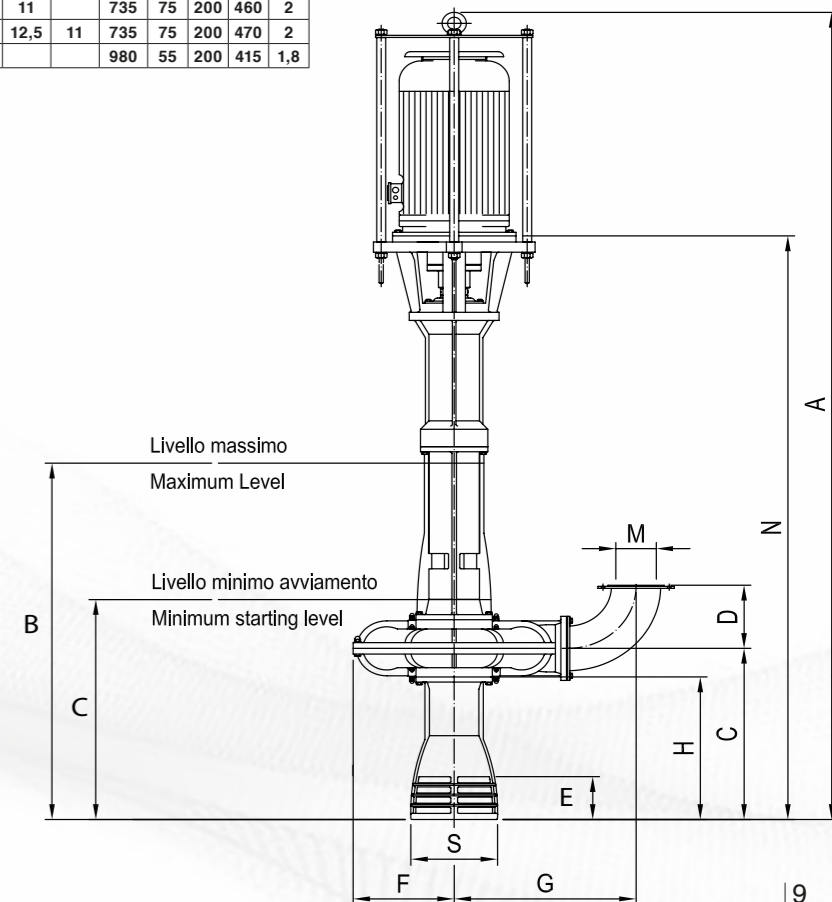



TOWER

VERTICAL ANTI-ABRASIVE PUMP WITH BELT COUPLING

FIELDS OF APPLICATION:

Special pumps designed and developed for conveying highly abrasive liquids from stone processing (workshops and sawmills), from the treatment/washing of aggregates, from the recovery of cementitious water and in the glass and ceramic processing sectors. Vertical axis with sealed chamber bearings dimensioned in such a way as to allow the lower part of the shaft to work overhanging without supports immersed in the liquid. The bodies are divided into two halves and coated with a special anti-abrasive moulded compound (consisting of replaceable and externally adjustable shells). The impeller is an anti-clogging open type consisting of a steel metal core coated with an anti-abrasive compound. An extension between the sucker and the lower body is possible, on request, to fit an extension between the intake- side strainer and the lower body to increase the maximum immersion height of the pump in order to avoid contact between the liquid to be pumped and the lower bearing (or to keep the electric Engine outside the tank/well). Coupled to the Engine by means of belts and pulleys, with the possibility of varying the speed and performance of the pump by adapting the electric Engine and the type of pulleys and belts.

TECHNICAL SPECIFICATIONS:

- AXIS:** Vertical pump with sealed chamber bearings sized to allow the lower part of the shaft to operate without supports immersed in the liquid.
- COUPLING:** Using V-belts with the possibility, by varying the size and type of belts and pulleys, to increase or decrease the flow rate/head of the pump itself (depending on the number of revolutions to be obtained). Depending on the performance required, the type of pump supplied can also be with direct coupling (PGM type). Both versions come complete with protective covers.
- BODY:** In cast iron divided into two halves with protective coating in our special moulded wear-resistant compound, consisting of replaceable shells that can be adjusted from the outside, both to allow rapid and convenient replacement and to eliminate any backlash caused by normal wear.
- OUTLET CURVE:** With interchangeable rubber sleeve for connecting the pump to the delivery pipe.
- IMPELLER:** Open-type anti-clogging, consisting of a steel core coated with a special anti-abrasive compound.
- SUCTION STRAINER:** Made of cast iron, specially sized and shaped for liquid suction.
- SUPPORT GROUP WITH RINGBOLT:** Usually provided because they are needed for lifting operations.
- PUMP STOP:** Bracket for fixing the pump to the wall.
- EXTENSION TO THE SUCTION STRAINER:** On specific request, there is the possibility of inserting an extension between the suction strainer and the lower body in order to increase the distance between the lower bearing and the liquid level, or to allow the electric Engine to remain outside the tank.



OPERATING CHARACTERISTICS

PUMPS	FLOW RATE																								RPM Speed	Ø. m Impeller								
	m3/h	12	18	24	30	45	60	75	90	105	120	135	150	180	210	240	270	300	330	360	390	420	450	480										
	I/1'	200	300	400	500	750	1000	1250	1500	1750	2000	2250	2500	3000	3500	4000	4500	5000	5500	6000	6500	7000	7500	8000										
TWR65		15	14,5	14	13,5	12	7,5																			1450	210							
		21	20,5	20	18,5	16																					1750	210						
		27,5	27	26,5	25	23																						2000	210					
TWR75		17,5	17	16,5	15	13	11																					1455	240					
		26	25,5	23,5	21,5	19																						1750	240					
		30	29,5	28	25,5	23																							1900	240				
TWR75S		20,5	20	18,5	16,5	14,5	12																						1460	265				
		30,5	30	28,5	26,5	24,5	21,5																						1750	265				
				18,5	18	17	16	15	13,5	12	10																			970	375			
TWR100					23	22	21	20	18,5	17	15,5	13,5																	1100	375				
					25	24	23	21,5	20	18,5	17	15																		1150	375			
						18,5	18	17,5	16,5	16	15,5	15	13,5	12	10	8														970	360			
TWR121						23	22,5	22	21,5	21	20	18,5	16,5	14,5	12,5															1100	360			
						25	24,5	24	23,5	22,5	21,5	20	18,5	16,5	14,5																1150	360		
							21	20,5	20	19,5	19	18	17	15,5	13,5	12	10														975	380		
TWR123						27	26,5	26	25,5	25	24	23	21,5	19,5	17,5	15															1100	380		
						29	28,5	28	27,5	27	26	24,5	23	21	19	17																1150	380	
						23	22,5	22	21,5	20,5	20	18,5	17	15,5	13,5	11,5																975	400	
TWR125							26	25,5	25	24,5	23,5	22	20,5	19	17	15															1050	400		
							29	28,5	27	26	25	23,5	21,5	19,5	17,5																	1100	400	
							15,5	15	14,5	14,5	14	13,5	13	12	11,5	11	10	8,5	7,5													735	440	
TWR158								20	19,5	19	18,5	18	17,5	17	16	15	14	13	12	11	10											980	390	
									23	22,5	22	21,5	20,5	20	19	18	17	16	15	14													1050	390
									25,5	25	24,5	24	23,5	22,5	21,5	20,5	19,5	18,5	17,5	16													1100	390
TWR168S																																735	465	
												23	22,5	22	21,5	20,5	20	19	18	17	16	15	14	13									980	415
													26,5	26	25,5	24,5	24	23	22	21	20	19	17,5	16									1050	415
TWR200																																	1100	415

Indicative data variable according to the nature of the liquid, geodetic head values (excluding pressure drops) rounded to the nearest 0.5 m

OVERALL DIMENSIONS

PUMPS	DIMENSIONS in mm												WEIGHT KG
	A	B	C	D	E	F	G	H	M	N	S	T	
65	2500	1060	420	175	105	205	440	330	70	1925	270	395	355
75	2630	1050	415	200	105	260	475	330	100	1925	270	395	390
75S	2630	1050	415	200	105	260	475	330	100	1925	270	395	415
100	3300	1450	515	205	115	360	580	400	100	2485	280	485	770
121	3350	1500	615	420	145	400	610	500	125	2535	240	485	840
123	3410	1500	615	420	145	400	610	500	150	2535	340	595	965
125	3410	1500	615	420	145	400	610	500	150	2535	340	595	1015
158	3870	1750	840	310	210	450	810	700	175	2775	385	595	1195
160	3870	1750	840	310	210	450	810	700	175	2775	385	595	1190
168S	3870	1750	840	310	210	450	810	700	175	2775	385	595	1230
200	3870	1750	840	310	210	450	810	700	175	2775	385	595	1340

Non-binding dimensions and weights

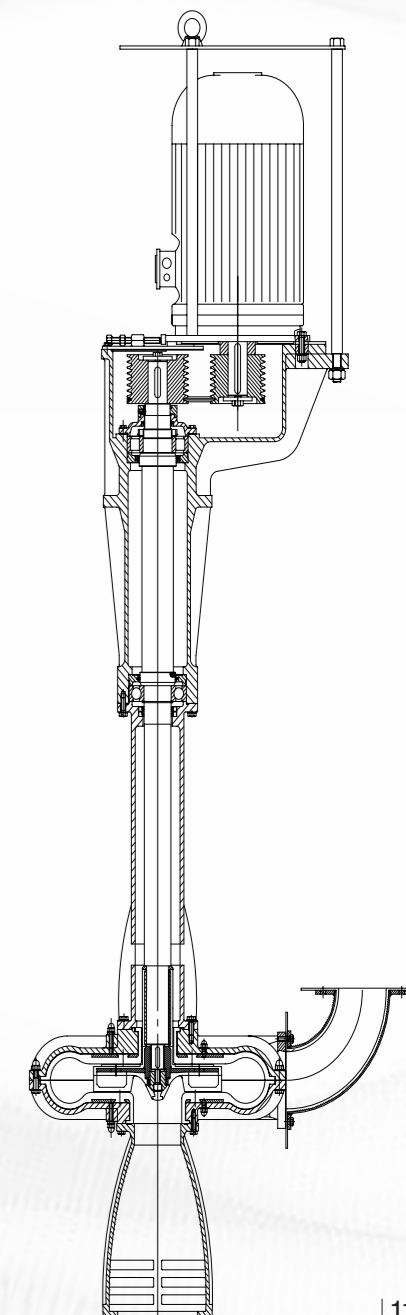
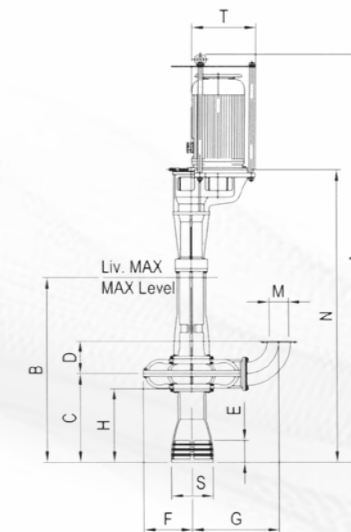



GEYSER

**VERTICAL PUMP
DESIGNED FOR DENSE SLUDGE**

FIELDS OF APPLICATION:

This is a type of pump traditionally and historically produced by Alfa. It has been designed to empty settling tanks and therefore to handle even particularly dense sludge (up to 2 kg/dm³).

The pump is immersed in the dense sludge, which falls into the pumping unit casing, which is made entirely of metal with a ductile iron impeller.

In addition, since the pumping unit is made of spheroidal cast iron and not of rubber, GEYSER series pumps can operate for short periods even in the absence of liquid.

A special feature of these pumps is the absence of a stuffing box, which would have a very short life in contact with the abrasive liquid. An anti-abrasive rubber tube is applied between the delivery curve of the pump and the fixed piping of the system to act as a vibration damper. Elastic joint coupling.

TECHNICAL SPECIFICATIONS:

AXIS: Vertical pump with sealed chamber bearings sized to allow the lower part of the shaft to operate without supports immersed in the liquid

BODY: In cast iron divided into two halves with protective coating in our special moulded wear-resistant compound, consisting of replaceable shells that can be adjusted from the outside, both to allow rapid and convenient replacement and to eliminate any backlash caused by normal wear.

OUTLET CURVE: With interchangeable rubber sleeve for connecting the pump to the delivery pipe.

IMPELLER: Spheroidal cast-iron channel.

SUPPORT GROUP WITH RINGBOLT: Usually supplied because they are necessary for lifting operations.

PUMP STOP: Bracket for fixing the pump to the wall.



OPERATING CHARACTERISTICS

PUMPS	FLOW RATE													Speed RPM	Engine kW
	m ³ /h	6	9	12	18	24	30	45	60	75	90	105	120		
GSR 40	l/1'	100	150	200	300	400	500	750	1000	1250	1500	1750	2000	1450	4
	m.c.a.	13	12,5	12	11	10	8,5								
GSR 80	m.c.a.					18	17,5	16,5	15,5	14,5	13,5	12	10,5	1450	15
	m.c.l.*	7,5	7	6,5	5	3,5									
	m.c.l.*					10,5	10	9	8	6,5	4				

Indicative data, at the delivery outlet, variable according to the nature of the fluid. Measurement with water.

* Capacities indicated for mixtures with 70% solids

- Maximum specific weight 2.5 kg/dm³.

OVERALL DIMENSIONS

PUMPS	DIMENSIONS in mm								WEIGHT Kg	WEIGHT Without Engine Kg
	A	B*	C*	E	G	H	M	S		
GSR 40	1610	900	150	130	315	200	70	280	145	114
GSR 80	2500	1550	180	155	430	275	100	365	350	265

Non-binding dimensions and weights

*B = MAXIMUM LEVEL

*C = MINIMUM LEVEL

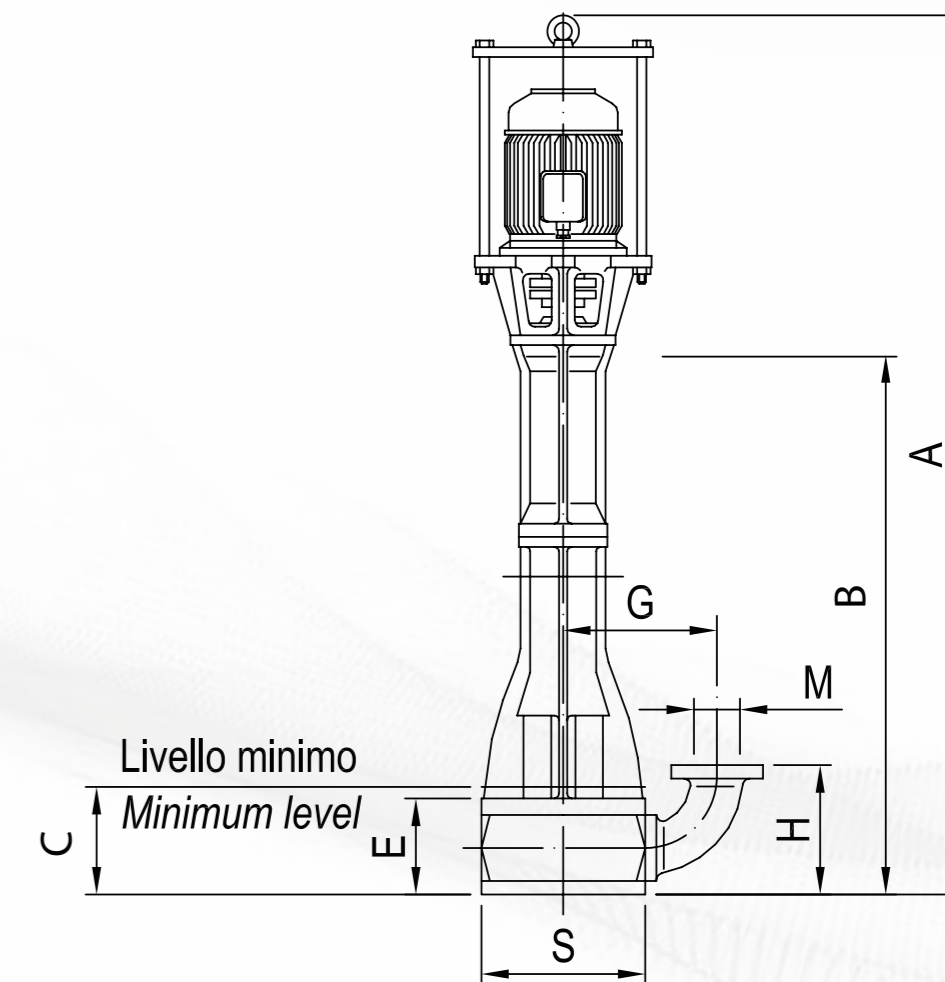



PANTERA

ANTI-ABRASIVE VERTICAL PUMP FOR HEAVY-DUTY APPLICATIONS

FIELDS OF APPLICATION:

Special pumps designed and engineered to operate in extremely harsh conditions handling highly abrasive fluids produced in quarries, mines, chemical and coal industries, with a vertical shaft without bearings immersed in the liquid and without seals that are application in tanks or wells and characterised by a completely cantilevered shaft, supported only externally. Body and impeller in anti-abrasive superalloy. Open impeller allowing the passage of even large solids given the applications. Coupling to the Engine by means of belts and pulleys, with the possibility of varying the revolutions and thus the performance of the pump.

OPERATING CHARACTERISTICS

PUMPS	Clear Water Performance								Sump Depth (mm)	Material of Wet Parts	Recommended Engine	Wt (kg)	Total Wt (kg)
	Capacity	Head Hw (m)	Speed n (r/min)	Eff. n %	No. of Vanes	Impeller Type	Vane Dia. (mm)	Particle Size (mm)					
	Q (m3/h)												
PNT 40 PV/SP	30	20	2017	40	5	Open	188	12	900	High Chrome	4P - 7.5 kW	285	285
PNT 65 QV/SP	80	30	1573	50,4	5	Open	280	15	1200	High Chrome	4P - 22 kW	432	432
PNT 100 RV/SP	180	30	1138	53,1	5	Open	370	32	1500	High Chrome	4P - 45 kW	867	867
PNT 150 SV/SP	380	30	966	53,2	5	Open	450	45	1800	High Chrome	4P - 90 kW	1737	1737
PNT 200 SV/SP	600	25	746	62	5	Open	520	65	1800	High Chrome	4P - 110 kW	2800	2800
	600	15	528	61,7	5	Open	575	65	1800	High Chrome	4P - 75 kW	3100	3100
PNT 250 TV/SP	720	15	544	62,9	5	Open	575	65	1800	High Chrome	4P - 75 kW	3100	3100
	900	15	557	60,2	5	Open	610	65	2100	High Chrome	4P - 90 kW	3500	3500
PNT 300 TV/SP	1080	15	574	61,4	5	Open	610	65	2100	High Chrome	4P - 110 kW	3500	3500
	1260	15	594	61,4	5	Open	610	65	2100	High Chrome	4P - 132 kW	3500	3500



PUMPS	FLOW RATE												Speed n (RPM)	No. Of Vanes	Impeller Type	Vane Ø (mm)	Sump Depth (mm)	Material of Wet Parts
	m ³ /h	10	20	30	40	60	80	100	200	300	400	500						
PNT 40 PV/SPR	7,9	6											1200	5	Open	188	900	Natural Rubber
	27,9	26	22,8	19									2200					
	52,7	50,5	47,5	43,3	38	32							3000					
PNT 65 QV/SPR	6,3	6	5,5										700	5	Open	280	1200	Natural Rubber
	22,8	22,3	22	20,3	18								1300					
			46	45,6	44	42	38,8						1850					
PNT 100 RV/SPR				8,6	8,4	8	7,6						600	5	Open	370	1500	Natural Rubber
				24,1	23,9	23,5	23	19,5					1000					
				47,8	47,3	46,9	46,3	42,8	36,9				1400					
PNT 150 SV/SPR								8,6	7,5				500	5	Open	450	1800	Natural Rubber
								22,8	21,7	19,7	17,3		800					
								35,7	34,6	32,8	30,2	27,1	1000					

OVERALL DIMENSIONS

PUMPS	DIMENSIONS in mm																				WEIGHT Kg			
	A	B	C	D	E	F	G	H	I	J	K	L	M	N	P	Q	S	T	U	V		W	Y	Z
PNT 40 PV/SP	Ø290	Ø230	75	85	133,5	4	16	18	374	153	285	900	130	88	DISCHARGE FLANGE 127 O.Ø - 40 I.Ø 4 HOLES Ø16 ON Ø98	N°4 - Ø18	450	500	450	500	Ø255	N°8 - Ø15	205	285
PNT 40 PV/SPR																								260
PNT 65 QV/SP	Ø362	Ø280	95	110	178	5	20	21	492	232	399	1200	227	123	DISCHARGE FLANGE 180 O.Ø - 65 I.Ø 4 HOLES Ø19 ON Ø140	N°4 - Ø18	620	680	620	680	Ø320	N°8 - Ø19	285	432
PNT 65 QV/SPR																								400
PNT 100 RV/SP	Ø500	Ø400	155	170	238	6	28	26	663	310	515	1500	265	195	DISCHARGE FLANGE 229 O.Ø - 104 I.Ø 8 HOLES Ø19 ON Ø191	N°4 - Ø22	930	1000	800	870	Ø445	N°8 - Ø23	400	867
PNT 100 RV/SPR																								800
PNT 150 SV/SP	Ø680	Ø550	200	211	300	5	20	25	878	375	665	1800	396	230	DISCHARGE FLANGE 280 O.Ø - 152 I.Ø 8 HOLES Ø22 ON Ø241	N°4 - Ø28	1030	1100	1030	1100	Ø610	N°8 - Ø27	500	1737
PNT 150 SV/SPR																								1500
PNT 200 SV/SP	Ø680	Ø550	200	211	300	10	32	32	878	439	771	1800	457	230	DISCHARGE FLANGE 343 O.Ø - 200 I.Ø 8 HOLES Ø22 ON Ø298	N°4 - Ø28	1200	1300	1100	1200	Ø610	N°8 - Ø27	600	2800
PNT 250 TV/SP	Ø860	Ø650	200	220	345	10	40	30	1338	471	903	2100	495	300	DISCHARGE FLANGE 406 O.Ø - 250 I.Ø 12 HOLES Ø25 ON Ø382	N°4 - Ø28	1650	1750	1350	1450	Ø760	N°8 - Ø39	700	3100
PNT 300 TV/SP	Ø860	Ø650	200	220	345	10	40	30	1338	583	942	2100	495	300	DISCHARGE FLANGE 483 O.Ø - 300 I.Ø 12 HOLES Ø25 ON Ø432	N°4 - Ø28	1650	1750	1350	1450	Ø760	N°8 - Ø39	700	3500

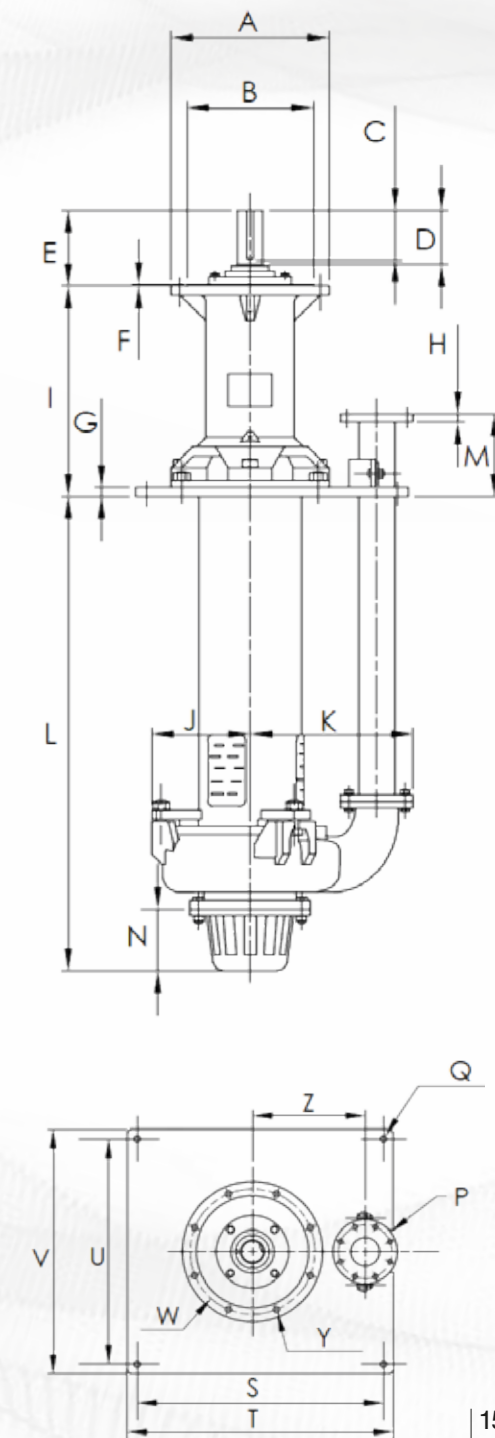



DRAGON

SPECIALISED VERTICAL PUMP FOR HIGHLY ABRASIVE LIQUIDS

FIELDS OF APPLICATION:

Special pumps designed and engineered for conveying highly abrasive liquids from stone processing (workshops and sawmills), from the treatment/washing of aggregates, from the recovery of cement water and in the glass and cement water to the glass and ceramic processing sectors.. Vertical axis with sealed chamber bearings dimensioned in such a way as to allow the lower part of the shaft to work without supports immersed in the liquid. The bodies are divided into two halves and coated with special anti-abrasive moulded compound (consisting of replaceable and externally adjustable shells). The impeller is open-type anti-clogging, is metallic and has improved performance and efficiency compared to a rubberized impeller; this means that it is possible to mount motors with lower power for the same performance. On specific request, an extension can be fitted between the impeller and the lower casing in order to increase the maximum immersion height of the pump so as to avoid contact between the liquid to be pumped and the lower bearing (or to keep the electric motor outside the tank/well). Direct coupling via two-piece elastic coupling. The capacity range of the DRAGON pumps is up to 5500 l/min.

TECHNICAL SPECIFICATIONS:

- AXIS:** Vertical pump axle with sealed chamber bearings dimensioned in such a way that the lower part of the shaft can work without supports immersed in the liquid.
- COUPLING:** By means of a two-piece flexible coupling complete with protective casing.
- BODY:** Made of cast iron divided into two halves with a protective coating of our special moulded wear-resistant compound, consisting of shells that can be replaced and adjusted from the outside, both to allow quick and convenient replacement and to eliminate any play caused by normal wear. In the smaller series the bodies are vulcanised, with shells only on customer request.
- OUTLET CURVE:** With interchangeable rubber sleeve for connecting the pump to the delivery hose.
- IMPELLER:** Anti-clogging open type, it is metallic with improved performance and efficiency, allowing the use of smaller motor sizes with the same performance.
- SUCTION STRAINER:** Made of cast iron, appropriately sized and shaped for liquid suction.
- BASE:** Frame for supporting pump on steel floor.
- SUPPORT GROUP WITH RINGBOLT:** Usually provided because they are needed for lifting and positioning operations.
- PUMP STOP:** Bracket for fixing the pump to the wall.
- EXTENSION TO THE SUCTION STRAINER:** On specific request, there is the possibility of inserting an extension between the suction pad and the lower body in order to so as to be able to increase the distance between the lower bearing and the liquid level, or to allow the electric motor to remain outside the outside the tank.

OPERATING CHARACTERISTICS

PUMPS	HEAD (m)	FLOW RATE								Speed RPM	Impeller Type	Vane Ø (mm)	Motor
		0	50	100	150	200	250	300	350				
DRG Ø400		54,5	54	52	49	46	42,5	38	33	1450	Open	400	4P - 55kW
DRG Ø370		47	45,5	43,5	41	37,5	34	29,5	25	1450	Open	370	4P - 45kW
DRG Ø350		42	40,5	38	35	31	26,5	22		1450	Open	350	4P - 37kW

NEW PROJECT

CFD DRAGON

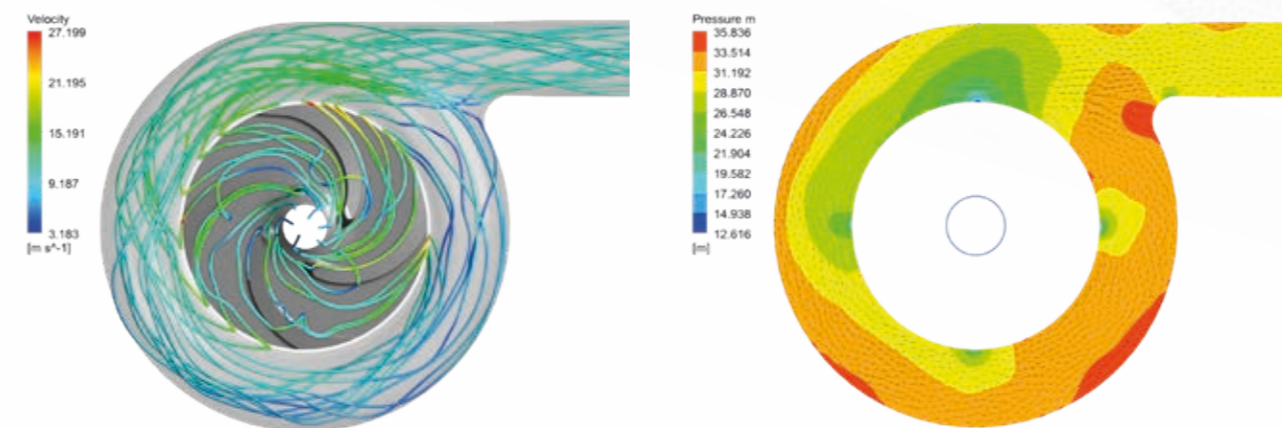

PUMPS COMPARISON

- DISCOVERER**
- TOWER**
- PANTERA**
- DRAGON**

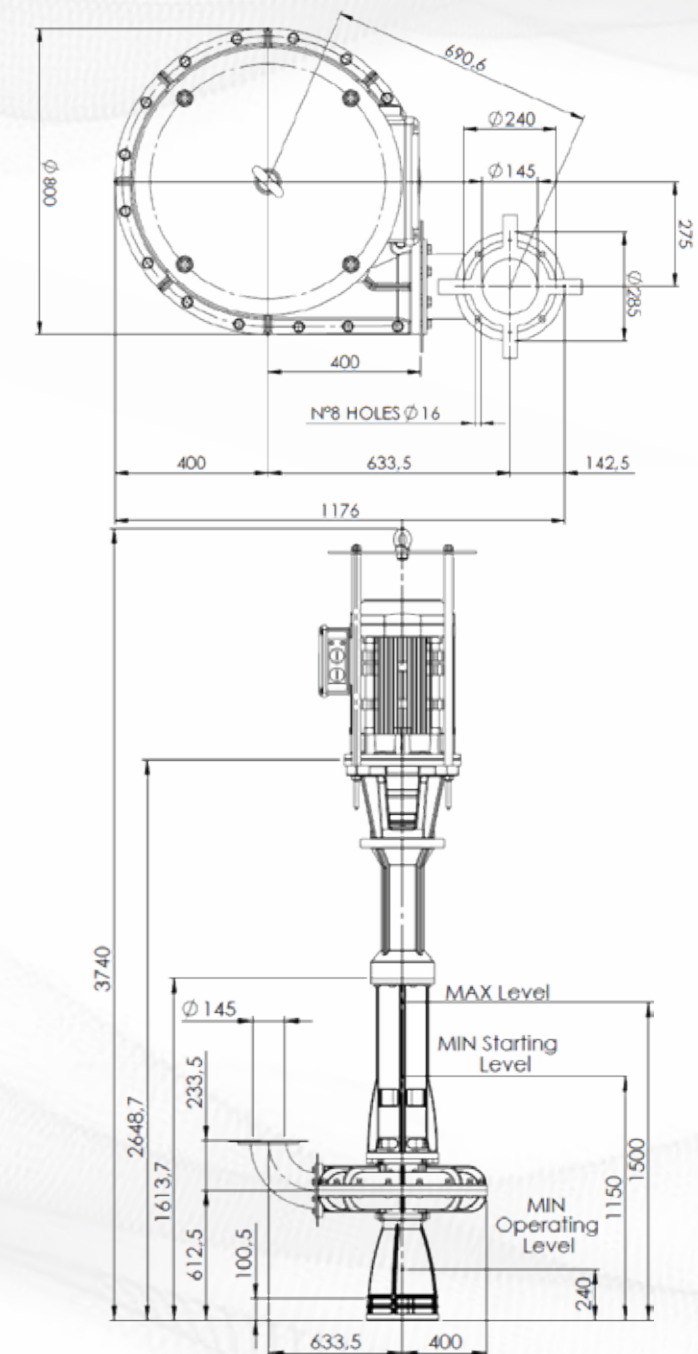
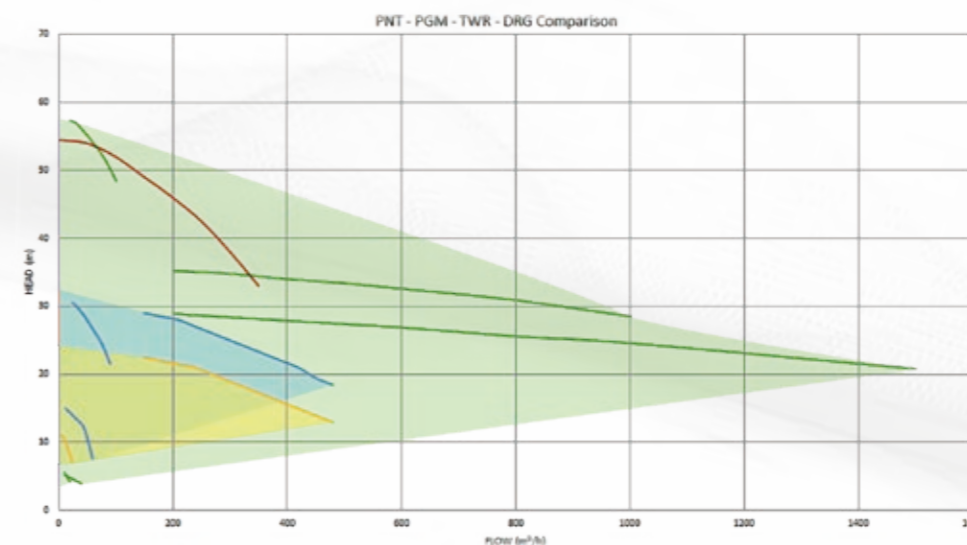



DIABLO

ANTI-ABRASIVE SUPERALLOY CENTRIFUGAL SINGLE-BODY HORIZONTAL AXIS PUMP

HPT
HIGH PRESSURE
TECHNOLOGY
READY

FIELDS OF APPLICATION:

A horizontal axis pump used to feed filter presses in the mining and aggregates sectors. It is a single-body pump capable of achieving a maximum closed pressure of 10 bar and a maximum flow rate range of 1000 l/min to 4000 l/min. Impeller, body and wear flange are made of super hard cast iron to withstand the maximum possible abrasion. It is equipped with tungsten carbide or silicon carbon mechanical seals flushed with clean water and oil-bath bearings. DIABLO pumps can be supplied with single or double speed motors and with standard coupling by means of belts and pulleys.

TECHNICAL SPECIFICATIONS:

AXIS: Horizontal pump axis with oil-bath lubricated bearings

COUPLING: By means of V-belts and pulleys with protective casing

BODY: No. 1 cast-iron chrome and vertical delivery

IMPELLER: N°1 in anti-abrasive super alloy open type pumps dynamically balanced with hardness of around 750-800 HB

SEALING GROUP: Double mechanical seal with silicon carbide or tungsten rings flushed with clean water.

BASE: Frame for supporting pump on steel floor.

OPERATING CHARACTERISTICS

PUMPS	FLOW RATE	PRESSURE (at pump outlet)		PIPES	
	(m3/h)	mH2O	bar*	Inlet DN	Outlet DN
DBL550-1H	60 - 70	63	8	100	50
DBL650-1H	90 - 120	65	8	100	50
DBL1025-1H	150-180	55	7.5	150	75
DBL1050-1H	200 - 250	70	9	200	125

*Pressure with sludge density 1.4 kg/dm³



HORIZONTAL PUMPS & FRONT SUCTION



DELTA

SUPERALLOY ANTI-ABRASIVE CENTRIFUGAL DOUBLE BODY HORIZONTAL AXIS PUMP

HPT
HIGH PRESSURE
TECHNOLOGY
16 BAR



HURACAN

SUPERALLOY ANTI-ABRASIVE CENTRIFUGAL TRIPLE BODY HORIZONTAL AXIS PUMP

HPT
HIGH PRESSURE
TECHNOLOGY
21 BAR

FIELDS OF APPLICATION:

A horizontal axis pump used to feed filter presses in the mining and aggregates sectors. It is a double-body pump capable of reaching a maximum closed pressure of 16-17 bar and with a maximum flow rate range of up to 9000 l/min. Impeller, body and wear flange are made of super hard cast iron to withstand the maximum possible abrasion. It is equipped with tungsten carbide or silicon carbon mechanical seals flushed with clean water and oil-bath bearings. DELTA pumps can be supplied with single or double speed motors and with standard coupling via belts and pulleys.

TECHNICAL SPECIFICATIONS:

AXIS: Horizontal pump axis with oil-bath lubricated bearings.

COUPLING: By means of belts and trapezoidal pulleys with protective casing.

BODY: N°2 in chrome cast iron with vertical delivery.

IMPELLER: No. 2 in dynamically balanced open-type anti-abrasive super alloy with hardness of approx. 750-800 HB.

BASE: Steel frame to support pump on the floor.

OPERATING CHARACTERISTICS

PUMPS	FLOW RATE	PRESSURE (at pump outlet)		PIPES	
	(m3/h)	mH2O	bar*	Inlet DN	Outlet DN
DLT550-2H	60 - 70	126	16	100	50
DLT650-2H	90 - 120	116	16	125	65
DLT1025-2H	150-180	120	16	150	100
DLT1050-2H	200 - 250	116	16	200	125
DLT220-2H	300 - 560	121	16	250	200

*Pressure with sludge density 1.4 kg/dm³



HORIZONTAL PUMPS & FRONT SUCTION

FIELDS OF APPLICATION:

A horizontal axis pump used to feed filter presses in the mining and aggregates sectors. It is a triple-body pump capable of reaching a maximum closed pressure of 20-21 bar and a maximum flow rate range of up to 4000 l/min. Impeller, body and wear flange are made of super hard cast iron to hard cast iron to withstand the maximum possible abrasion. It is equipped with tungsten carbide or silicon carbon mechanical seals flushed with clean water and bearings in an oil bath. oil-bath bearings. HURACAN pumps can be supplied with single- or double-speed motors and with coupling standard by means of belts and pulleys.

TECHNICAL SPECIFICATIONS:

AXIS: Horizontal pump axis with oil-bath lubricated bearings.

COUPLING: By means of belts and trapezoidal pulleys with protective casing.

BODY: N°3 in chrome cast iron with vertical delivery.

IMPELLER: No. 3 in dynamically balanced open-type anti-abrasive super alloy with hardness of approx. 750-800 HB.

BASE: Steel frame to support pump on the floor.

OPERATING CHARACTERISTICS

PUMPS	FLOW RATE	PRESSURE (at pump outlet)		PIPES	
	(m3/h)	mH2O	bar*	Inlet DN	Outlet DN
HRC550-3H	60 - 70	158	21	100	80
HRC650-3H	90 - 120	150	21	125	100
HRC1050-3H	200 - 250	150	21	200	150

*Pressure with sludge density 1.4 kg/dm³



HORIZONTAL PUMPS & FRONT SUCTION



LEVANTE

HORIZONTAL SINGLE-BODY CENTRIFUGAL RUBBER LINED PUMP



EVO

HORIZONTAL DOUBLE-BODY CENTRIFUGAL RUBBER LINED PUMP



FIELDS OF APPLICATION:

A horizontal axis pump used to feed filter presses in the marble and granite industry. It is a single-body pump capable of reaching a maximum indoor pressure of 6-7 bar and a maximum flow rate range of up to 5000 l/min. The impeller is made of super hard cast iron, while the body, which can be separated into two halves, is internally lined with an anti-abrasive natural rubber vulcanised onto the cast iron. It is equipped with silicon carbide mechanical seals flushed with clean water and bearings in an oil bath. LEVANTE pumps can be supplied with single or double speed motors and with standard coupling by means of belts and pulleys.

TECHNICAL SPECIFICATIONS:

AXIS: Horizontal pump axis with oil-bath lubricated bearings.

COUPLING: By means of belts and trapezoidal pulleys with protective casing.

BODY: N°1 in chrome cast iron with vertical delivery.

IMPELLER: No. 1 dynamically balanced open-type anti-abrasive super alloy with hardness of approx. 750-800HB

BASE: Steel frame to support pump on the floor.

OPERATING CHARACTERISTICS

PUMPS	FLOW RATE (m3/h)	PRESSURE (at pump outlet)		PIPES		IMPELLER Ømm
		mH2O	bar*	Inlet DN	Outlet DN	
LVT350-1G	10-20	30	4	65	40	155
LVT450-1G	30-40	40	5	80	50	200
LVT550-1G	50-60	45	6	100	65	250
LVT650-1G	90-120	55	7	125	80	300
LVT1025-1G	150-180	55	7	150	100	350
LVT1050-1G	200-250	45	6	200	150	400

*Pressure with sludge density 1.4 kg/dm³

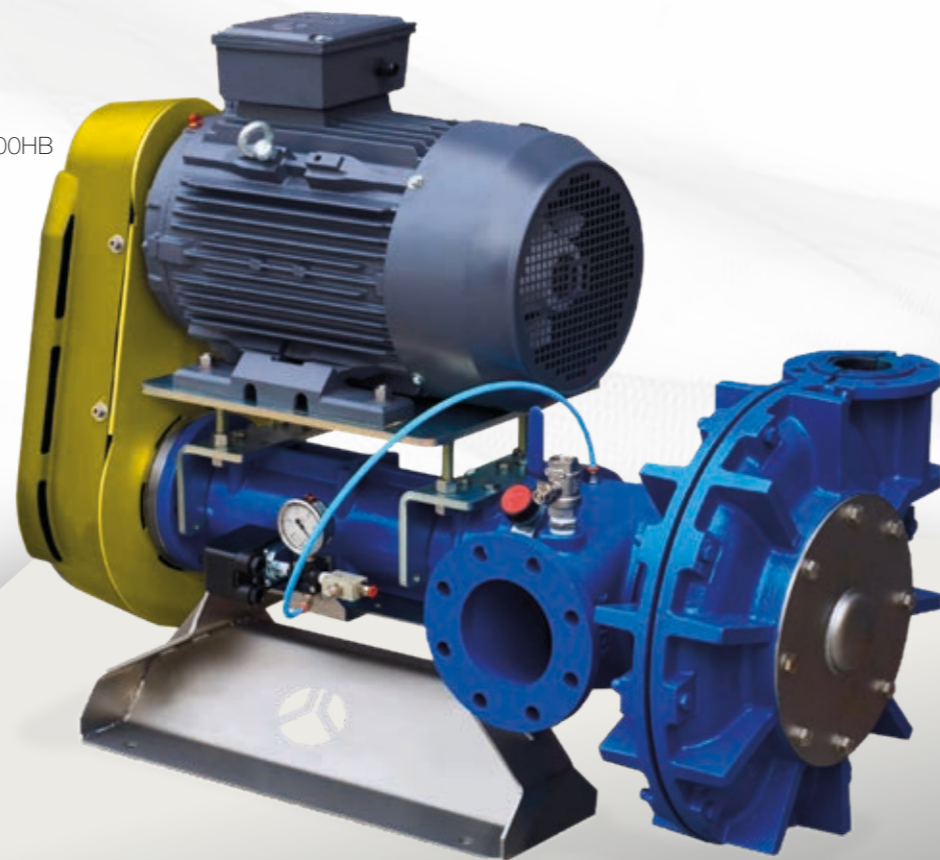

HORIZONTAL PUMPS & FRONT SUCTION

FIELDS OF APPLICATION:

A horizontal axis pump used to feed filter presses in the marble and granite industry. It is a double-body pump capable of reaching a maximum closed pressure of 12-13 bar and a maximum flow rate range of up to 5000 l/min. The impeller is made of super hard cast iron while the bodies, which can be separated into two halves, are internally lined with an anti-abrasive natural rubber vulcanised onto the cast iron. It is equipped with silicon carbide mechanical seals flushed with clean water and bearings in an oil bath. EVO pumps can be supplied with single or double speed motors and with standard coupling by means of belts and pulleys.

TECHNICAL SPECIFICATIONS:

AXIS: Horizontal pump axis with oil-bath lubricated bearings.

COUPLING: By means of belts and trapezoidal pulleys with protective casing.

BODY: N°2 in chrome cast iron with vertical delivery.

IMPELLER: No. 2 in dynamically balanced open-type anti-abrasive super alloy with hardness of approx. 750-800 HB.

BASE: Steel frame to support pump on the floor.

OPERATING CHARACTERISTICS

PUMPS	FLOW RATE (m3/h)	PRESSURE (at pump outlet)		PIPES		IMPELLER Ømm
		mH2O	bar*	Inlet DN	Outlet DN	
EVO550-2G	60-70	95	13	100	65	200
EVO650-2G	90-120	95	13	125	80	300
EVO1050-2G	200-250	100	13	200	150	400

*Pressure with sludge density 1.4 kg/dm³



HORIZONTAL PUMPS & FRONT SUCTION



ENOLA

HORIZONTAL AXIS CENTRIFUGAL PUMP

FIELDS OF APPLICATION:

Horizontal axis pump used to feed small to medium-sized filter presses in the marble and granite industry. The impeller has a metal core and is lined with anti-abrasive natural rubber as is the body that can be separated into two halves and has replaceable shells. It is equipped with water-fluxed silicon carbide mechanical seals and gas-lubricated bearings. ENOLA pumps can be supplied with single or double speed motors and with coupling by means of belts and pulleys or with coaxial coupling.

TECHNICAL SPECIFICATIONS:

AXIS: Horizontal pump axis with grease-lubricated bearings.

COUPLING: Via belts and trapezoidal pulleys with protective casing or via elastic coupling.

BODY: No. 1 cast iron with anti-abrasive rubber shell or vulcanised.

IMPELLER: No. 1 with metal core coated with anti-abrasive rubber, dynamically balanced open type.

SEALING GROUP: Double mechanical seal with silicon carbide or tungsten rings flushed with clean water.

BASE: Steel frame for supporting the pump on the floor.



HORIZONTAL PUMPS & FRONT SUCTION



OPERATING CHARACTERISTICS

PUMPS	FLOW RATE								PRESSURE BAR			Speed RPM	Engine KW	PIPES Ø mm
	m3/h	3,6	7,2	12	18	24	30	36	48	Weight spe. max.				
PSO 45	60	120	200	300	400	500	600	800	1,3	1,5	1,6	2900	1	50
PSO 50	40	39	38	37	35	30	-	-	5,2	6	-	2900	15	50
PSO 55	10	9,5	9	7,5	6	-	-	-	1,3	1,5	-	1450	11/9	50
	40	39	38	37	-	-	-	-	5,2	6	-	2900	2/4 p.	50

Indicative data variable according to the nature of the fluid, measured at the pump port.

OVERALL DIMENSIONS

PUMPS	DIMENSIONS in mm																	COMPLETE	ONLY PUMP
	DMA	DNM	A	B	C	F	G	H	I	L	M	N	P	Q	R	S	Z		
PSO 45	80	40	155	740	175	200	-	315	205	1050	650	960	450	300	295	85	22	305	150
PSO 50	80	40	155	740	175	200	-	315	205	1050	650	960	450	300	295	85	22	315	150
PSO 55	80	40	155	740	175	200	-	315	205	1050	650	960	450	300	295	85	22	315	150

Non-binding dimensions and weights.

OPERATING CHARACTERISTICS PSO 75

PUMPS	FLOW RATE								PRESSURE BAR			Speed RPM	Engine KW	PIPES Ø mm
	m3/h	3,6	7,2	12	18	24	30	36	48	Weight spe. max.				
PSO 75	11	11	10,5	10	9,5	9	8	6	1,4	1,6	1,7	1150	18,5/15 2/4 p.	70
	43,5	43,5	43	42	40,5	-	-	-	5,6	6,5	6,9	2300		
	12,5	12,5	12	11,5	11	10,5	10	8	1,6	1,8	-	1230		
	49,5	49	48,5	47,5	46	-	-	-	6,4	7,4	-	2450		
	14	14	13,5	13	12,5	12	11	9	1,8	-	-	1300		
	56	55,5	55	54	53	-	-	-	7,3	-	-	2600		

Indicative data variable according to the nature of the fluid, measured at the pump port.

OVERALL DIMENSIONS PSO 75

PUMPS	DIMENSIONS in mm																	COMPLETE	ONLY PUMP
	DMA	DNM	A	B	C	F	G	H	I	L	M	N	P	Q	R	S	Z		
PSO 75	80	70	182	260	235	200	160	315	240	720	652	570	950	860	153	115	22	415	185

Non-binding dimensions and weights.

HORIZONTAL PUMPS & FRONT SUCTION

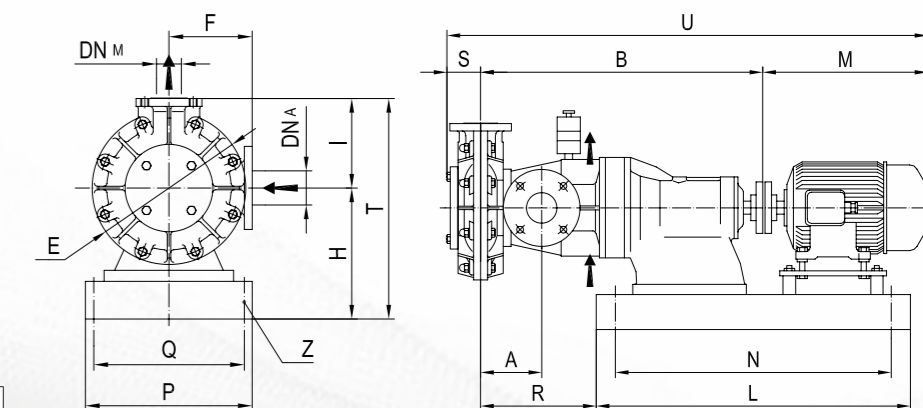
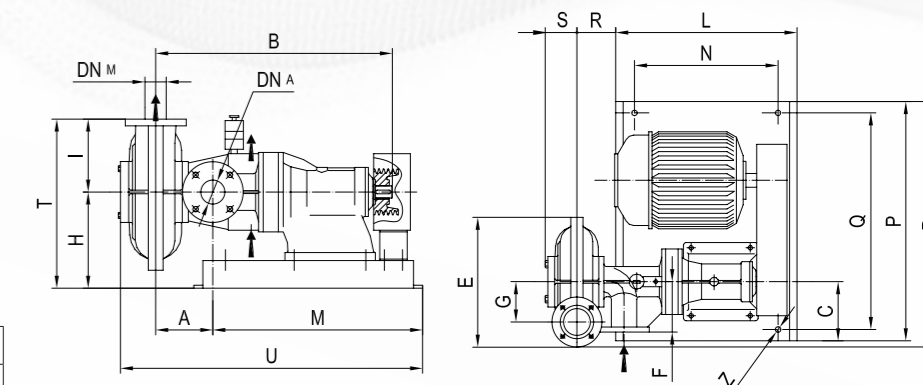



WALF

**FRONT SUCTION PUMPS
HYDROCYCLONES**

FIELDS OF APPLICATION:

Guaranteeing high flow rates and high heads, they are ideal pumps for use in the industrial and service sectors. They are used to feed hydrocyclones in the inert treatment and washing sector and in all areas where there is a need to transfer abrasive and/or acidic liquids. The bodies and impellers can be made of cast super alloys with high resistance to mechanical abrasion ((hardness of around 800 HB is possible), or to be coated with special anti-abrasive rubber compounds.

OPERATING CHARACTERISTICS

PUMPS	SxD	ALLOWABLE MATING MAX. POWER (KW)	MATERIAL (IMPELLER)	CLEAR WATER PERFORMANCE					IMPELLER	
				CAPACITY m ³ /h	HEAD (m)	SPEED (rpm)	Max eff. h%	NPSH (m)	N. OF VANES	VANE DIA. (mm)
1.5/1B - AH	1,5X1	15	AO5	10-30	5-85	1200-4400	52	3.2-8	5	152
2/1.5B - AH	2X1.5	15	AO5	20-60	6-60	1200-3200	45	3-8	5	184
3/2C - AH	3X2	30	AO5	40-138	10-85	1200-3170	64	3-12	5	214
4/3C - AH	4X3	30	AO5	50-250	8-80	1000-2750	68	3-10	5	245
4/3D - AH	4X3	60	AO5						5	245
6/4D - AH	6X4	60	AO5	100-400	10-78	800-1800	72	2-12	5	365
6/4E - AH	6X4	120	AO5						5	365
8/6E - AH	8X6	120	AO5	300-800	10-80	500-1300	72	2-10	5	510
8/6F - AH	8X6	260	AO5						5	510
10/8E - M	8X6	300	AO5	500-1500	10-85	400-1000	70	2-12	5	686
10/8F - AH	10X8	260	AO5						5	686
10/8ST - AH	10X8	560	AO5	500-200	8-82	300-900	80	2-8	5	762
12/10ST - AH	12X10	560	AO5						5	965
14/12ST - AH	14X12	560	AO5	1000-2900	10-86	300-700	77	2-13	5	965
16/14TU - AH	16X14	1200	AO5	1000-3500	10-62	250-550	82	3-10	5	1067
WITH SPECIAL ANTI-ABRASIVE RUBBER										
1.5/1B - AHR	1,5X1	15	R55	10-25	8-46	1400-3200	50	3.6-7.5	3	152
2/1.5B - AHR	2X1.5	15	R55	20-50	5-42	1000-2600	50	2-5	5	180
3/2C - AHR	3X2	30	R55	30-78	6-46	900-2300	62	3-4	5	215
4/3C - AHR	4X3	30	R55	50-150	5-40	800-1950	68	2-8	5	245
4/3D - AHR	4X3	60	R55						5	245
6/4D - AHR	6X4	60	R55	100-320	10-42	800-1350	72	2-6	5	365
6/4E - AHR	6X4	120	R55						5	365
8/6E - AHR	8X6	120	R55	200-680	6-50	400-1000	70	2-10	5	510
8/6F - AHR	8X6	260	R55						5	510
10/8E - MR	8X6	300	R55	400-1050	10-50	400-750	76	2-12	5	686
10/8F - AHR	10X8	260	R55						5	686
10/8ST - AHR	10X8	560	R55	400-1050	8-44	300-650	81	2-8	5	762
12/10ST - AHR	12X10	560	R55						5	965
14/12ST - AHR	14X12	560	R55	1000-2300	10-44	300-500	79	2-8	5	965
16/14TU - AHR	16X14	1200	R55	1000-2850	10-42	250-450	82	3-8	5	1067

Available in superalloy or rubberised.



HORIZONTAL PUMPS & FRONT SUCTION



HYDRA

CLEAR WATER PUMPING GROUP

FIELDS OF APPLICATION:

Clear water pumping units that integrate perfectly into the process water purification and recycling plant. Monobloc horizontal axis pumps are used, with bodies and impellers in cast iron, bronze or stainless steel, mechanical seals in widia or steel, shafts in hardened steel or stainless steel.

OPERATING CHARACTERISTICS

PUMPS	PERFORMANCE						
	FLOW RATE		HEAD (m)	POWER (kW)	PASSAGE FREE (mm)	FREQUENCY (Hz)	DIAMETER MANDATORY
	(m ³ /h)	(l/m)					
HYDRA 1000	60	1000	60	22	100	50	DN100
HYDRA 10000	600	10000	50	132	300	50	DN300
HYDRA 11000	720	12000	50	132	300	50	DN300
HYDRA 13000	780	13000	50	250	350	50	DN350



PUMPS FOR CLEAR WATER PUMPING UNIT



NAUTILUS

SUBMERSIBLE PUMPS

FIELDS OF APPLICATION:

Submersible pump used to feed decanters with abrasive liquids produced in the marble and granite industry, in aggregate washing or in the ceramic industry. It is placed inside deep tanks or wells where a vertical pump cannot be used. The bodies are divided into two halves and lined internally with replaceable abrasion-resistant natural rubber shells. The impeller is an open type consisting of a steel metal core lined with abrasion-resistant rubber. The capacity range of the NAUTILUS pumps is up to 2250 l/min.

OPERATING CHARACTERISTICS

PUMPS	FLOW RATE															Shaft Seal	Speed	Engine	Pipes	Impeller	Weight spec.
	m ³ /h	6	9	12	18	24	30	45	60	75	90	105	120	135	150						
	I/1'	100	150	200	300	400	500	750	1000	1250	1500	1750	2000	2250	2500	RPM	kw	Ø mm	Ø mm	max Kg/dm ³	
NTL45	HEAD mt	11	10,5	10	8,5	7	-	-	-	-	-	-	-	-	-	MS	1425	4	60	180	1,7
NTL75		-	-	-	17,5	17	16,5	15	13	11	-	-	-	-	-	MS	1455	7,5	100	240	1,3
NTL75S		-	-	-	-	20,5	20	18,5	16,5	14,5	12	-	-	-	-	MS	1450	11	100	265	1,3
NTL100/325		-	-	-	-	-	31	30	29	28	26	24	22	20	-	MS	1450	22	100	325	1,3

OVERALL DIMENSIONS

PUMPS	DIMENSIONS in mm																			DNM	WEIGHT kg
	A	D	F	G	H	I	K	L	N	O	P	S	U	V	W	Z	Y				
NTL45	786	121	175	370	165	181	-	505	241	350	40	628	N°4 HOLES Ø14	165	-	125	205	50	110		
NTL75	859	121	256	427	187	208	456	505	296	512	58	793	N°4 HOLES Ø14	220	160	180	240	100	193		
NTL75S	954	121	256	427	187	208	456	600	296	512	58	793	N°4 HOLES Ø14	220	160	180	240	100	223		
NTL100/325	1363	200	360	507	187	311	565	822	496	720	45	977	N°4 HOLES Ø14	220	250	180	320	100	418		

Non-binding dimensions and weights.

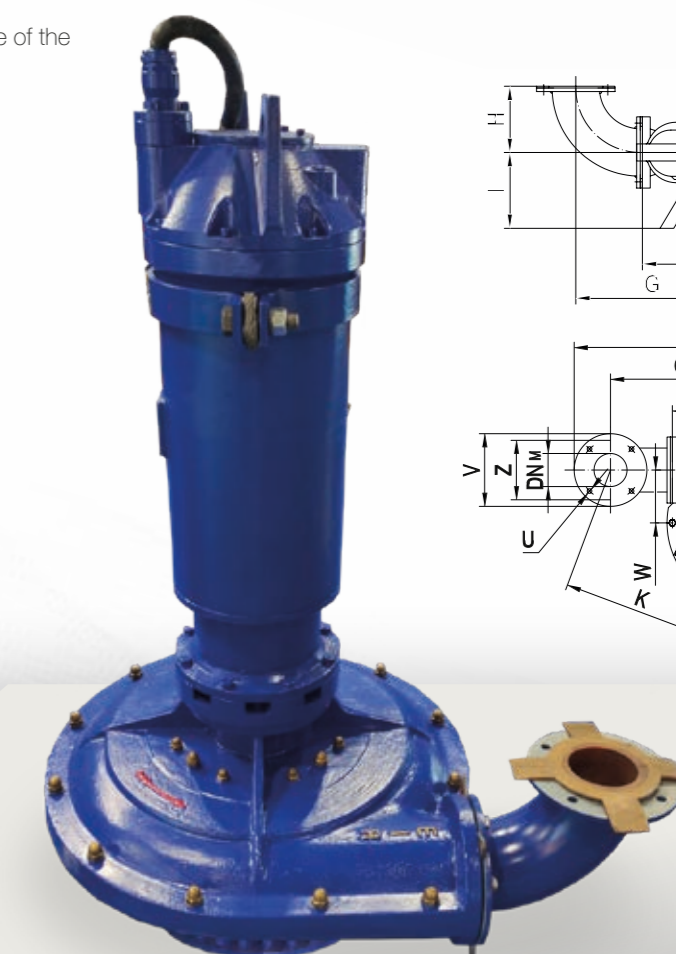
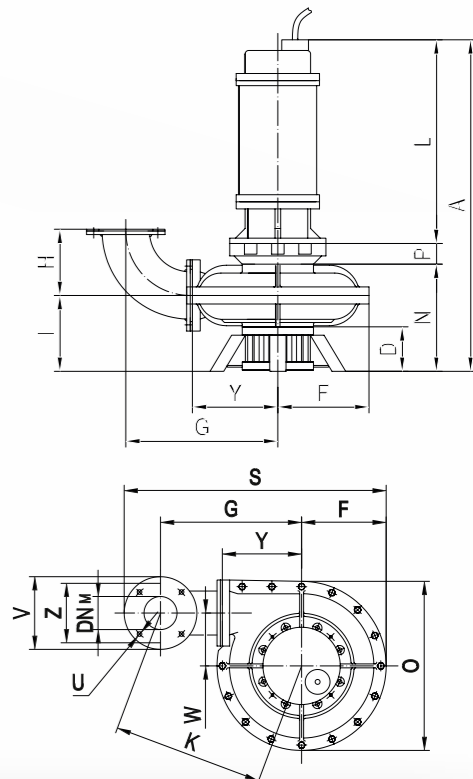



BARRACUDA

SUBMERSIBLE WASTE WATER TREATMENT PUMP

FIELDS OF APPLICATION:

Submersible pumps designed and engineered for wastewater treatment in the industrial, domestic, agricultural and hospital sectors. The flow rate range of these pumps goes from 1000 l/min to 10000 l/min with head around 15 m and power ratings from 7.5 kW to 37 kW. These pumps are mechanically sealed and have a cast iron bodies and impellers while the shaft is made of steel.

OPERATING CHARACTERISTICS

PUMPS	FLOW RATE													Shaft Seal	Speed RPM	Engine kW	Material Casing/Impeller/Shaft	PH/Hz
	m3/h	12	24	36	48	60	90	120	180	240	300	360	600					
BRC 100	22,4	22,5	22,5	22,4	22,1	21	-	-	-	-	-	-	-	MS	1425	7,5	cast iron / cast iron / 45# steel	3/400/50
BRC 150 - 15	-	-	17,4	17,4	17,4	17,2	16,8	14,9	-	-	-	-	-	MS	1455	15	cast iron / cast iron / 45# steel	3/400/51
BRC 200 - 22	-	-	-	-	19,5	19,2	18,8	18,1	16,7	14,6	12,5	-	-	MS	1450	22	cast iron / cast iron / 45# steel	3/400/52
BRC 200 - 30	-	-	-	-	-	19,4	19,2	18,7	17,8	16,6	15	-	-	MS	1450	30	cast iron / cast iron / 45# steel	
BRC 250 - 37	-	-	-	-	-	-	19,1	18,7	18,1	17,5	16,7	11,1	-	MS	1450	37	cast iron / cast iron / 45# steel	
BRC 250 - 45	-	-	-	-	-	-	22,2	21,7	21,1	20,6	19,7	15,1	-	MS	1450	45	cast iron / cast iron / 45# steel	

OVERALL DIMENSIONS

PUMPS	DIMENSIONS in mm							
	A	B	C	D	E	F	G	H
BRC 100 - 7,5	745	510	170	Ø100	Ø170	Ø210	430	N°4 - Ø18
BRC 150 - 15	980	660	255	Ø150	Ø225	Ø265	590	N°8 - Ø18
BRC 200 - 22	1230	830	290	Ø200	Ø280	Ø320	580	N°8 - Ø18
BRC200 - 30	1170	780	290	Ø200	Ø280	Ø320	680	N°8 - Ø18
BRC250 - 37	1420	950	345	Ø250	Ø335	Ø250	780	N°12 - Ø18
BRC250 - 45	1530	1000	345	Ø250	Ø335	Ø375	780	N°12 - Ø18

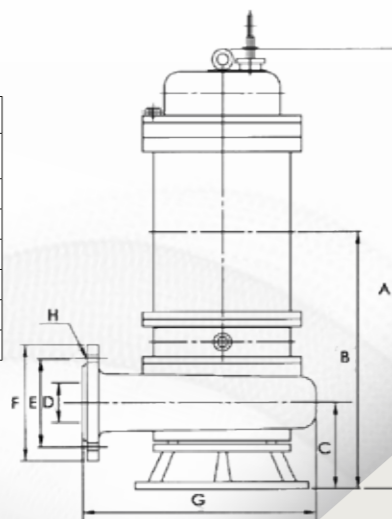

SHARK

SUBMERSIBLE PUMP FOR FEEDING DECANTERS WITH ABRASIVE LIQUIDS

NEW PROJECT

FIELDS OF APPLICATION:

Submersible pump used to feed decanters with abrasive liquids produced in the marble and granite industry, for washing aggregates or in the ceramic industry. Used inside tanks or deep wells where it is not possible to use a vertical pump. The bodies are divided into two halves and internally lined with replaceable non-abrasive natural rubber shells. The impeller is of the open type, it is metallic and has improved performance and efficiency compared to a rubberized impeller; this involves the possibility of mounting motors of lower power with the same performance. The flow rate range of SHARK pumps reaches up to 5500 l / min.

TECHNICAL SPECIFICATIONS:

AXIS: Vertical pump axis with impeller keyed directly onto the motor shaft.

BODY: Made of cast iron divided into two halves with protective coating in our special moulded wear-resistant compound, consisting of shells that can be replaced and adjustable from the outside, both to allow quick and convenient replacement and to eliminate any play caused by normal wear.

OUTLET CURVE: With interchangeable rubber sleeve for connecting the pump to the delivery pipe.

IMPELLER: Anti-clogging open type, it is metal with improved performance and efficiency, allowing the use of smaller size motors for the same performance.

SUCTION STRAINER: Made of cast iron, specially sized and shaped for liquid suction.

OPERATING CHARACTERISTICS

PUMPS	HEAD (m)	FLOW RATE								Speed RPM	Impeller Type	Vane Ø (mm)	Motor
		0	50	100	150	200	250	300	350				
SRK Ø400	54,5	54	52	49	46	42,5	38	33	1450	Open	400	4P - 55kW	
SRK Ø370	47	45,5	43,5	41	37,5	34	29,5	25	1450	Open	370	4P - 45kW	
SRK Ø350	42	40,5	38	35	31	26,5	22		1450	Open	350	4P - 37kW	



CFD SHARK

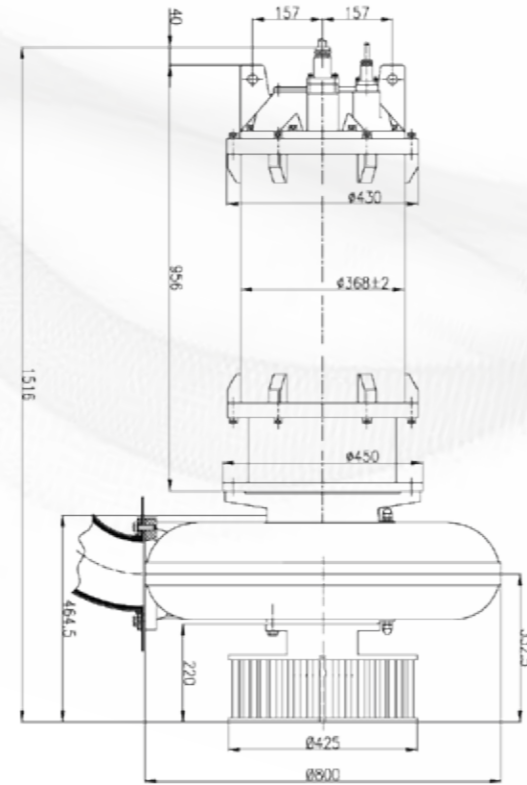
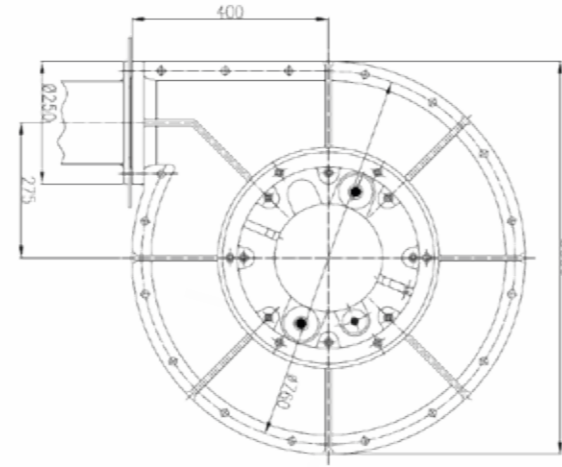
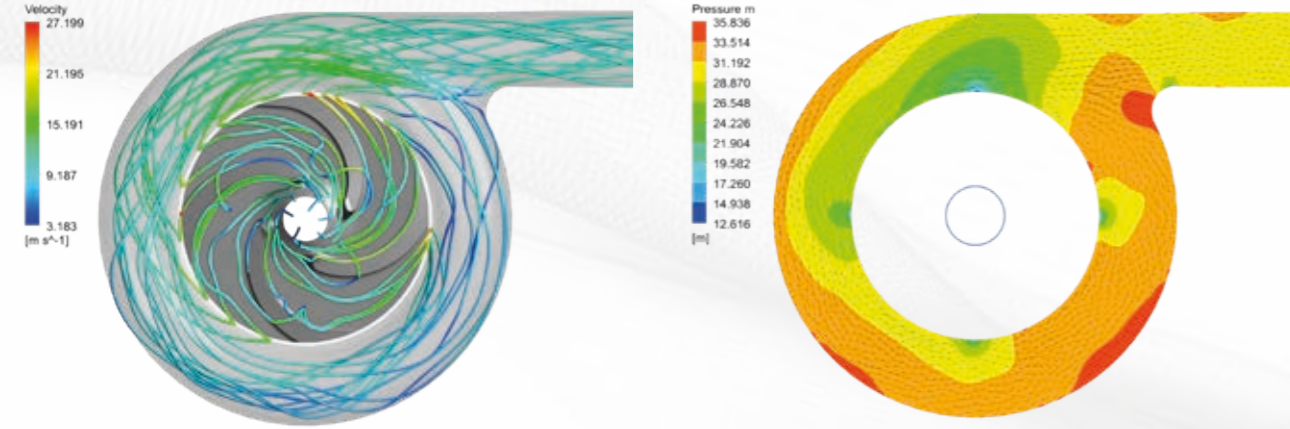

PUMPS COMPARISON

- NAUTILUS
- BARRACUDA
- SHARK

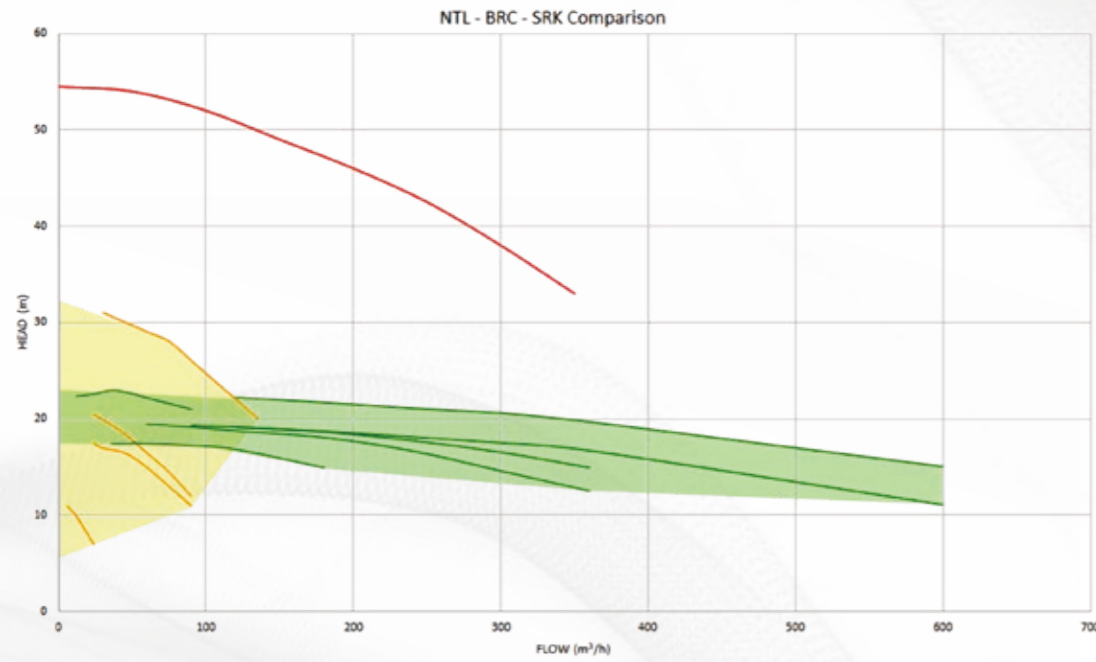

OTHER PUMPS

PNEUMATIC DIAPHRAGM PUMPS

A diaphragm pump is a positive-displacement pump that uses flexible diaphragms that alternate back and forth, creating a temporary chamber.



SCREW PUMP

This type of pump is used to handle large flow rates. These pumps are also used when the DOSON is included.

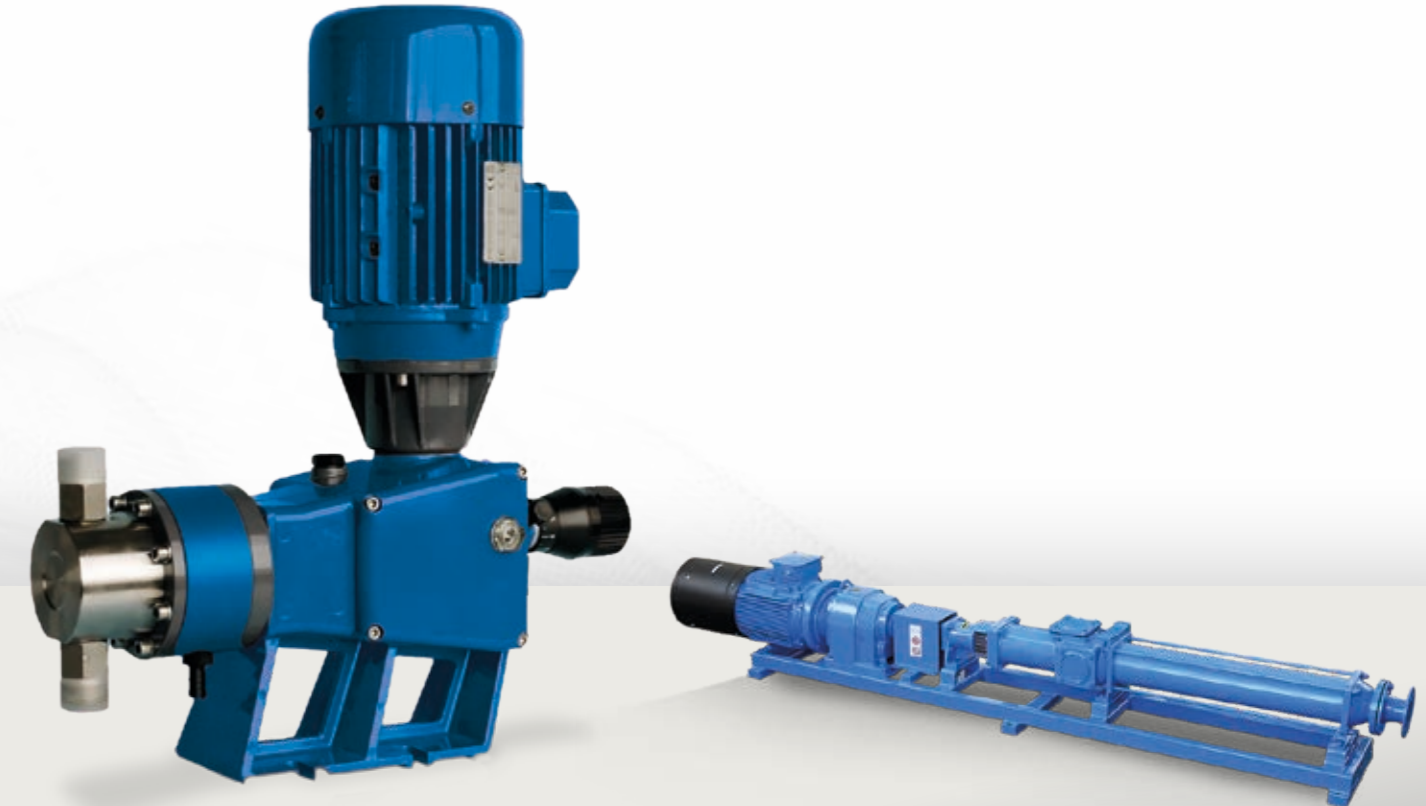

PISTON PUMP

This type of pump is used to handle small and medium flow rates. Generally, the maximum flow rate handled with these pumps is 500 l/h of flocculant solution.



VALVES

MANUAL OR PNEUMATIC

OPERATING CHARACTERISTICS:

Manually operated valves with an aluminium body and rubber sleeve designed for abrasive mixtures. Depending on the internal diameter of the sleeve itself, they are manufactured with either external or internal clamps. Valves that are pneumatically operated (open pressure) with an aluminium body and rubber sleeve designed for abrasive mixtures. They are produced with single or double cylinders. In the rest position they are closed and opening takes place with the introduction of air.



VALVE A SLOTS
manual



SPHERE VALVE
manual or pneumatic



CLAMP VALVE
manual or pneumatic



BUTTERFLY VALVE
manual or pneumatic



KNIFE GATE VALVE
manual or pneumatic

VALVES WITH ANTI-ABRASIVE RUBBER SLEEVES | MANUAL CONTROL

CODE	TYPE	DIMENSIONS in mm											WEIGHT Kg
		DN	E	H	I	L	R	S	FLANGE				
									C	D	HOLES		
diam.	n°												
V25	1C	25	115	147	58	105	60	115	85	115	14	4	2
V40*	1C	40	165	245	105	155	100	172	125	165	14	4	5
V50	1C	50	175	261	118	160	110	172	125	165	14	4	5
V70	1C	70	204	364	156	190	150	202	160	200	14	4	8
V100	1C	100	270	441	200	246	170	269	180	220	14	4	12
V125	2C	125	346	410	135	285	190	315	210	250	16	4	27
V150	2C	150	400	585	170	300	240	337	240	285	16	4	36
V175	2C	175	400	680	180	350	280	385	270	315	16	8	37
V200	2C	200	470	750	205	340	300	383	295	340	16	8	49
V250	2C	250	625	899	256	500	367	530	350	395	22	12	98

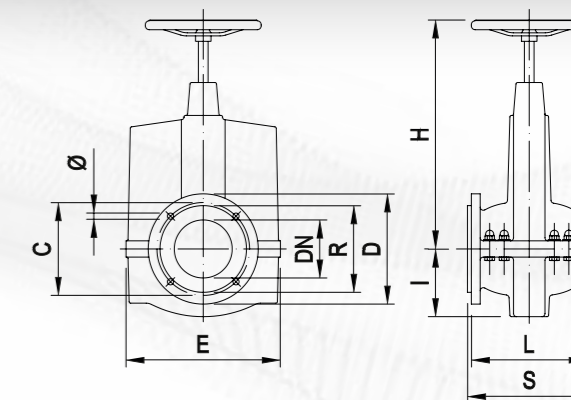

SLEEVE VALVES SERIES VPA-VPA2 | PNEUMATIC CONTROL

CODE	TYPE	DIMENSIONS in mm										WEIGHT Kg		
		DN	E	H	I	L	S	M	V	FLANGE				
										C	D		HOLES	
diam.	n°													
VPA25	1C	25	150	265	40	160	170	-	1/4" G	85	115	14	4	5,2
VPA40	1C	40	200	365	75	200	210	-		110	150	18	4	11
VPA50	1C	50	200	380	83	230	240	-		125	165	18	4	12
VPA65	1C	65	200	400	93	290	305	-		145	185	18	4	16
VPA80	1C	80	285	560	180	310	330	-		160	200	18	4	32
VPA280	2C	80	165	-	-	250	270	675		160	200	18	4	28
VPA2100	2C	100	200	-	-	300	320	700		180	220	18	8	30
VPA2125	2C	125	245	-	-	300	320	870		210	250	18	8	47
VPA2150	2C	150	245	-	-	300	337	900		240	285	22	8	55
VPA2200	2C	200	285	-	-	340	380	1030		295	285	22	8	72

1-CYLINDER VALVE (TIPO 1C) "VPA"

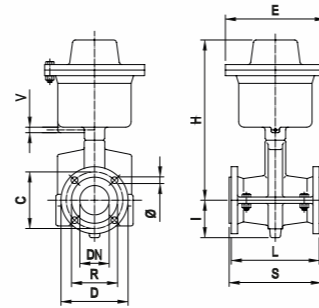

2-CYLINDER VALVE (TIPO 2C) "VPA2"

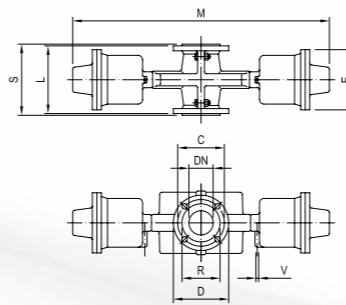

AUTOMATIC FILTERS

FILTERS WITH BATTERIES OF AUTOMATIC MEDIUM/HIGH FLOW VALVES

Materials covered:

- quartz sand for DP.
- activated carbon for KP.
- catalytic mixture based on Pyrolusite (manganese dioxide) for DFP.
- battery valve set composed by 5 diaphragm valves in cast iron, for models up to DN100 size.
- battery valve set composed by 5 butterfly valves, for models starting from DN100 size.
- distribution system made of ABS and PP and arm collector system.



PIPES & FLANGES

SPECIAL ANTI-ABRASIVE HOSES

PIPES			
CODE	A	B	WEIGHT Kg
TUG35	35	49	1,3
TUG60	60	70	1,8
TUG68	70	80	2,3
TUG99	101	111,5	3,5
TUG100	100	130	9,1
TUG125	127	155	10,5
TUG150	152	184	15
TUG180	180	205	12,2
TUG200	203	230	16,4
TUG250	254	285	22,7
TUG300	305	336	27,9

STEEL FLANGES							
CODE	DN	DIMENSIONS			HOLES		WEIGHT Kg
		C	D	S	Diam.	n°	
FA25	25	85	115	10	14	4	0,6
FA50	50	125	165	10	14	4	1,5
FA70	70	160	200	10	14	4	2
FA100	100	180	220	10	14	4	2,2
FA125	125	210	250	10	16	4	2,5
FA150	150	240	285	10	16	4	3,3
FA170	170	270	315	10	16	8	3,8
FA200	200	295	340	10	16	8	4
FA250	250	350	395	20	20	12	14
FA300	300	400	445	20	22	2	17

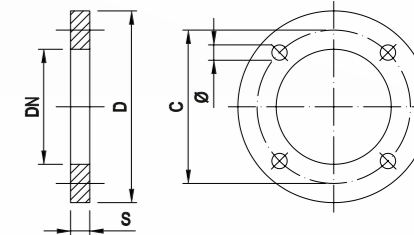
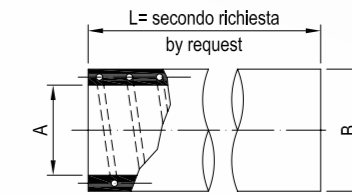

ANTI-ABRASIVE RUBBER HOSE FLANGES

RUBBER HOSE FLANGES										
CODE	TYPE	C	D	E	I	L	S	HOLES		WEIGHT Kg
								Diam.	n°	
FB25	1	85	115	33	-	100	10	14	4	1
FB50	1	125	165	60	-	90	10	14	4	1,9
FB70	1	160	200	70	-	90	10	14	4	3
FB99	1	180	220	100	-	160	10	14	4	3,2
FT100	2	180	220	-	127	155	20	16	4	3,6
FT125	2	210	250	-	154	160	22	18	4	4,4
FT150	2	240	285	-	183	180	22	18	4	6
FT170	2	270	315	-	204	200	25	18	8	8,2
FT200	2	295	340	-	229	200	25	18	8	8,5
FT250	2	350	395	-	284	250	20	20	12	25
FT300	2	400	445	-	335	250	25	22	12	33

FLANGE TYPE "1" (one-piece steel)

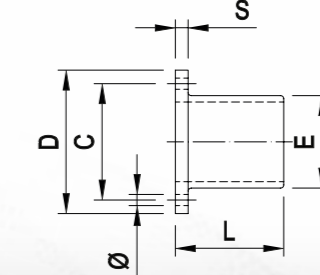

FLANGE TYPE "2" (one-piece aluminium)

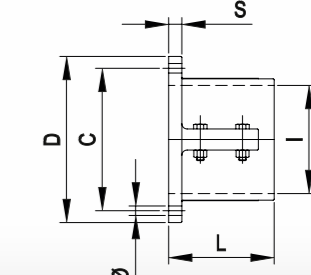



SPARE PARTS

IMPELLERS - BENDS - SHAFTS AND RUBBERISED BODIES

IMPELLERS



BENDS



SHAFTS



RUBBERISED BODIES





Via Trento 132/A

37020 Dolcè (VR) - Italy

Tel: +39 045 729005

info@alfapumps.it

P.IVA / VAT: IT00235680238

www.alfapompe.it



A COMPANY OF

MATEC[®]
INDUSTRIES